



Technical Information
WM400

WasteMaster





WasteMaster is an innovative on-site food and organic waste valorising system which accelerates the decomposition of food waste, reducing it to a much smaller quantity of dry and odour-free residual material. The valorising process is facilitated by a unique proprietary technology, without the need for water, enzymes, microorganisms or any other elements.

SIMPLE USER FRIENDLY OPERATION

The WasteMaster system is safely and simply operated by a single button on the bin lifter for the automatic loading system.



FULL VISIBILITY OF CONVERSION PROCESS

WasteMaster's touch screen facilitates real-time monitoring of the valorising process. WasteMaster will unload automatically when the process has finished.



AUTOMATIC DETECTION

Sensors are present throughout the system to monitor performance continuously. A sensor detects when a residue bin is present and also when the bin is full and ready to be replaced.



REMOTE COMMUNICATIONS FOR DIAGNOSTIC REPORTING AND DATA COLLECTION

The WasteMaster system via a 4G/5G SIM network and has the functionality to generate reports on actual food waste volumes generated, to suit a customer's specific requirements.



SIMPLE INSTALLATION

WasteMaster can be very easily installed. All that is required is a three-phase power supply and an air outlet.



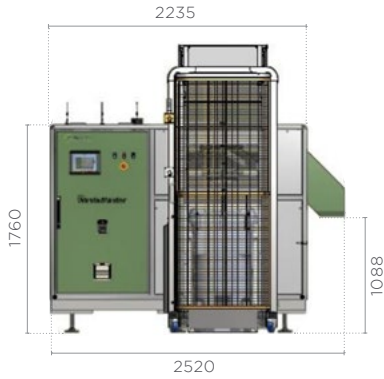

Front View Hatch fully opened and bin lifter presented

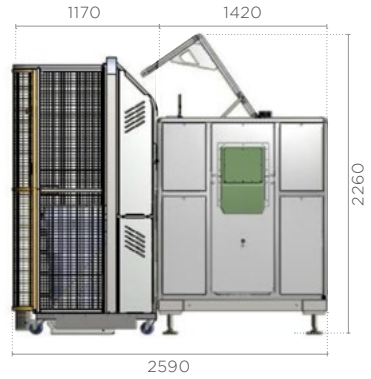

Side View Hatch fully opened

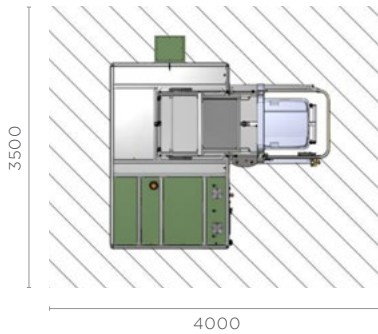

Plan View of required working area



Dimensions (L, D, H)	2520 x 1420 x 1760	mm
Dimension Inc Bin Lifter (L, D, H)	2520 x 2590 x 2260	mm
Maximum loading door height	2350 Includes Bin Lifter	mm
Working Area	3500 x 4000 Includes Bin Lifter	mm
Machine Weight	1395	kgs
Daily Volume Capacity	up to 400	kgs
Total Loaded Weight	1795	kgs
Power Supply	32 amp 3-phase circuit, hardwired	
IP Rating	54	
Noise Level	<85	dBA
Air Outlet	150mm	mm
Comms Requirement	Network, Wifi or 4G/5G SIM	

Machine Specifications

Specifications, appearance and equipment are subject to change without notice by reason of improvement. Hazard prevention measures have been removed from the photos featured in this document.



To ensure safe operation, please consult the operator's manual before use.



We develop, supply and manage innovative, safe, efficient and environmentally beneficial on-site solutions for the re-purposing of putrescible waste into reusable resources.

We support customers with process improvements to deliver savings in all aspects of their organic waste management.

Green Eco Technologies is focussed on reducing the overall impact of food waste disposal for businesses, institutions and organisations, and the environment.

Headquartered in Melbourne, Australia.
Offices in UK, UAE, Singapore, Spain and Chile.

For further information about WasteMaster:

Green Eco Technologies

A 1-3 Molan St,
Ringwood, VIC, 3134

P 1800 614 272

E hello@greenecotec.com

W www.greenecotec.com

